



## Lubrication of Electric Motors

In servicing electric motor bearings, it is important that the right grease be applied in the right quantity. Both underlubrication and overlubrication are harmful. Underlubrication will result in bearing failure through inability of the insufficient amount of lubricant to perform successfully any one of its functions. Excess grease in the path of rotating parts offers high resistance to motion, and overheating and high internal pressure will result. Excessive leakage at bearing seals may occur.

The frequency of regreasing antifriction bearings of electric motors is affected by the following factors:

- Quality of grease used, especially as to its service life
- Severity of service, including operating temperatures
- Cleanliness of surroundings
- Presence of water
- Continuity of service (may range from infrequent operation to 24-hour-a-day operation)
- Bearing size
- Speed and housing design

In many applications, motor bearings are greased once a year during routine inspection and maintenance work. In general, large electric motors (greater than 40 hp) should be greased more frequently, such as every six months. Small motors operating under non-severe conditions and using high-quality grease may not require regreasing for periods of up to several years.

### Relubrication Volume Formula

The amount of grease needed depends on bearing size. Bearing manufacturers use a variety of formulas, but experience has shown that the following works well:

**Metric:**  $Gq = 0.005 \times D \times W$

$Gq$  = Grease replenishment amount (gm)

$D$  = Bearing outside diameter (mm)

$W$  = Bearing width (mm)

**English:**  $G = 0.1 \times D \times W$

$G$  = Grease replenishment amount (oz)

$D$  = Bearing outside diameter (in.)

$W$  = Bearing width (in.)

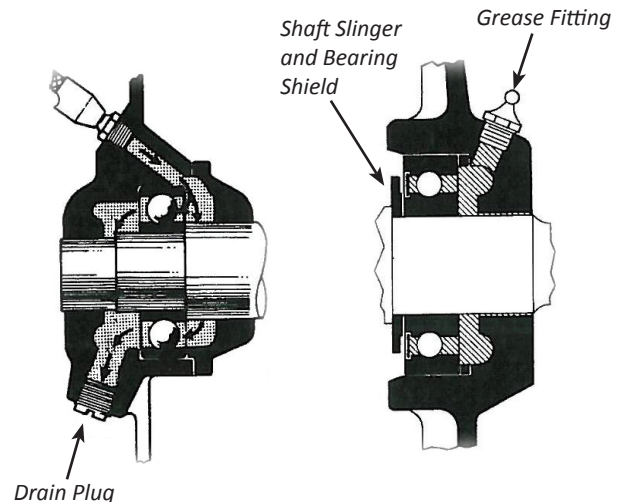

To use this formula, you must know the size of the bearing as well as how much each pump of the gun delivers. Grease guns come in a variety of pump sizes, typically dispensing 1 to 3 gm (0.03 to 0.1 oz) per stroke. We suggest you pump grease into a small container of known volume and count the number of strokes to fill it. From this, you can figure the volume per stroke of the gun.

Ideally the following procedures should be followed when regreasing electric motor bearings:

### A. Bearing with fitting and relief plug

1. Stop the motor.\* (If motor is stopped, use any required lockout/tagout procedures.)
2. Wipe clean the pressure gun fittings and relief plugs on the motor and the grease gun tip.
3. Remove the relief plug to avoid damaging the bearing seals or forcing grease out along the motor shaft.
4. Free the relief hole of any hard grease.
5. Put the gun on the fitting and pump the proper calculated amount of grease into the bearing until fresh grease comes out the hole.
6. Run the motor. The grease will come out of the hole. Continue to run until the pressure is relieved. Thirty minutes will be plenty of time
7. Clean and replace the relief plug.



### **B. Bearing with fitting and no relief plug**

1. Stop the motor.\* (If motor is stopped, use any required lockout/tagout procedures.)
2. Wipe clean the pressure gun fittings and the fitting on the grease gun.
3. Put the gun on the fitting and pump the proper calculated amount of grease into the bearing.
4. Remove the grease fitting.
5. Run the motor to allow the grease to come back out of the hole until pressure is relieved.

*If no grease comes out of the hole, the bearing was apparently quite dry.*

6. Repeat Steps 3 and 4 until grease will back out of the hole with the fitting removed and allow pressure to relieve when the motor is running.
7. Clean and replace the grease fitting.

### **C. Bearing with relief-type fitting and no relief plug**

1. Stop the motor.\* (If motor is stopped, use any required lockout/tagout procedures.)
2. Wipe clean the pressure gun and grease gun fittings.
3. Put the gun on the fitting and pump the proper calculated amount of grease into the bearing until the grease comes out of the relief hole.

*If after considerable pumping, grease does not come out of the relief hole, the relief slot may be plugged.*

4. Remove the grease fitting.
5. Clean out the slot, replacing it with a new fitting if cleaning is not possible.
6. Replace the fitting and repeat Step 3.

### **D. Bearing with single plug only (no fitting)**

1. Stop the motor.\* (If motor is stopped, use any required lockout/tagout procedures.)
2. Clean the area around the plug and the grease gun fitting.
3. Remove the plug.
4. Insert a fitting of the proper pipe size that will match the gun.
5. Put the gun on the fitting, then pump grease into the bearing, pumping only half the calculated amount of grease at first.

6. Remove the grease fitting.
7. Run the motor. Allow the grease to come back out of the hole until the pressure is relieved.  
*If no grease comes out of the hole, the bearing was apparently quite dry.*
8. Repeat Steps 5, 6 and 7 until the grease comes back out of the hole with the fitting removed. Allow the grease to come back out of the hole until the pressure is relieved.
9. Replace the plug.

### **E. Bearing with automatic lubricator and relief plug**

1. Stop the motor.\* (If motor is stopped, use any required lockout/tagout procedures.)
2. Wipe grease from the grease fitting. Clean dirt, debris and paint from around the grease relief plug. This prevents foreign objects from entering the grease cavity.
3. Remove the grease relief plug and remove any hardened grease.
4. Wipe clean the end of the grease gun, attach it to the fitting, then pump in a few shots of grease, making sure there is no back pressure to impede flow.
5. Install lubricator with predetermined discharge period. (Adaptors and support may be needed.)
6. Place motor back into service.

\*If the lubrication or purging of this unit can be done safely while the motor is running, re-lubrication can be done without shutting down the motor.

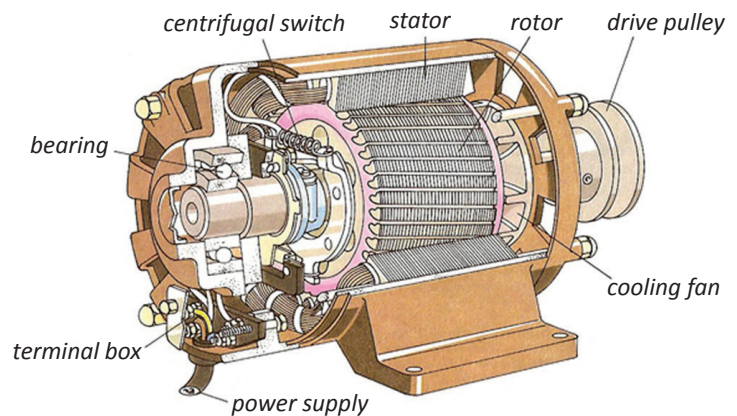

Photo courtesy of *The Internet Encyclopedia of Science*.