

Product Information



Xclude™ Contamination Exclusion

Xclude™ High Humidity Check Valve Breather

Ideal solution to protect against moisture and particulate contamination in low-flow applications with intermittent operations

Typical Industries

- Wind Energy
- Pulp & paper
- Aviation
- Storage
- Manufacturing
- Petrochemical

Applications

- Gearboxes
- Low-flow
- High-humidity
- Washdown





Xclude™ High Humidity Check Valve Breather

By the Numbers

1–Domed Cap

Allows for better washdown runoff.

2–Integrated Nylon Standpipe

Provides excellent vibration resistance and dissipates impact throughout the unit, eliminating weak points. It also allows even airflow distribution throughout the unit, eliminating inaccurate readings of desiccant saturation.

3–External Ribs on Shell

Create greater durability and grip when installing or replacing breather.

4–Integrated Drip Ring

Prevents water from entering vent holes.

5–Threaded Mounting

Easily replaces standard filler/breather cap with multi-fit connection or one of several adapters.

6–Larger, High-Capacity Check Valves

Allow for increased airflow at low cracking pressure.

7–Polyester Filter Element

Removes airborne contamination to 3-micron absolute. Unique loops allow particles to release during system exhalation, helping to increase breather life.

8–Enhanced Seal

Eliminates potential for airflow bypass.



How It Works

This breather unit replaces the standard dust cap or OEM breather cap on equipment. Check-valves on the bottom of the unit isolate the system until equipment needs to breathe. As air is drawn into equipment through the breather, the layered filter elements remove particulates while the desiccant beads strip harmful moisture.

While in service or during shutdown, the desiccant beads attract moisture from inside the equipment reservoir, actively drying the equipment.



Materials & Components

- Filter housing: Polycarbonate, nylon, polypropylene, Buna-N, silicone
- Filter media: Polyurethane, polyester
- Hydrophilic media: Silica gel

Filter Efficiency

- 3 μ absolute ($\beta_{3\geq 200}$)

Recommended Temperature Range

- 20°F to 200°F (-29°C to 93°C)

Chemical Compatibility

- Compatible with all mineral oils, most synthetic oils and diesel.
- Contact your local consultant for chemical compatibility inquiries.

Certificates and Approvals

- Upon request

Breather Specifications

Breather Sizing / Air Flow Guidelines

Model	Amount of Desiccant (lb / kg)	Adsorption Capacity (fl oz / ml)	Air Flow Rate (cfm @ 1 Psid)	Air Flow Rate (gpm / lpm)	Max Suction & Return Rate (gpm / lpm)	Gearbox & Storage Tank Reservoir Size (gallons / liters)	Hydraulic Reservoir Size (gallons / liters)
LEXHHCV375-13	.1 / .06	.8 / 23	1	11 / 41	11 / 41	15 / 57	2 / 8
LEXHHCV375-28	.3 / .1	2 / 50	3	11 / 41	11 / 41	35 / 132	5 / 19
LEXHHCV1-66	.8 / .4	5 / 144	12	90 / 340	90 / 340	200 / 757	60 / 227
LEXHHCV1-122	1.4 / .6	9 / 253	11	82 / 311	82 / 311	350 / 1,325	100 / 379
LEXHHCV1-188	2 / .9	12 / 359	10	75 / 283	75 / 283	500 / 1,893	200 / 757

Note: These are general guidelines for sizing; other considerations, such as: humidity level, frequency of air flow, ambient temperatures, and chemical compatibility are very important in sizing a breather properly. Larger applications and special circumstances require thorough analysis. Please contact LE for assistance in breather sizing for your application.

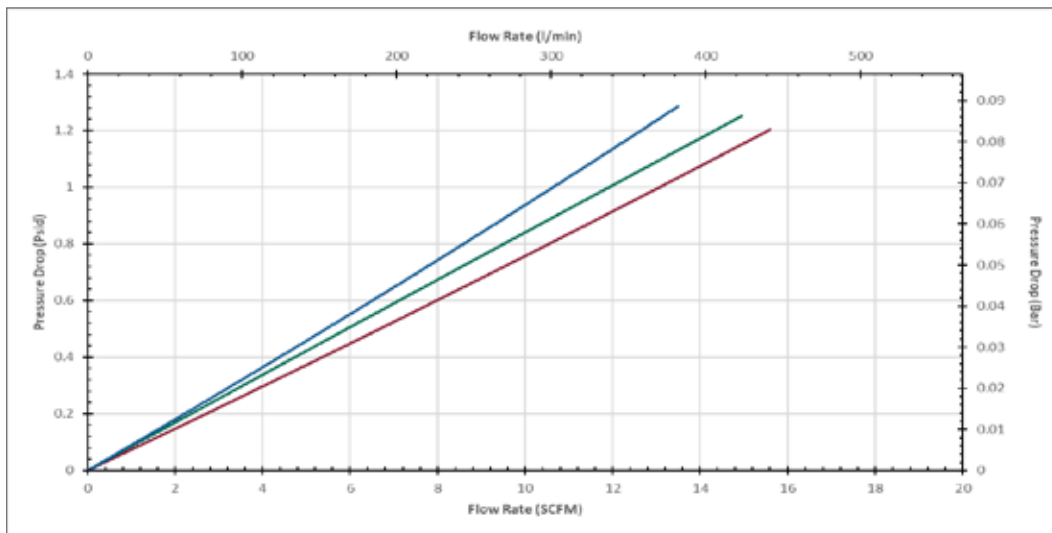

- LEXHHCV1-66
- LEXHHCV1-122
- LEXHHCV1-188



Additional Specs

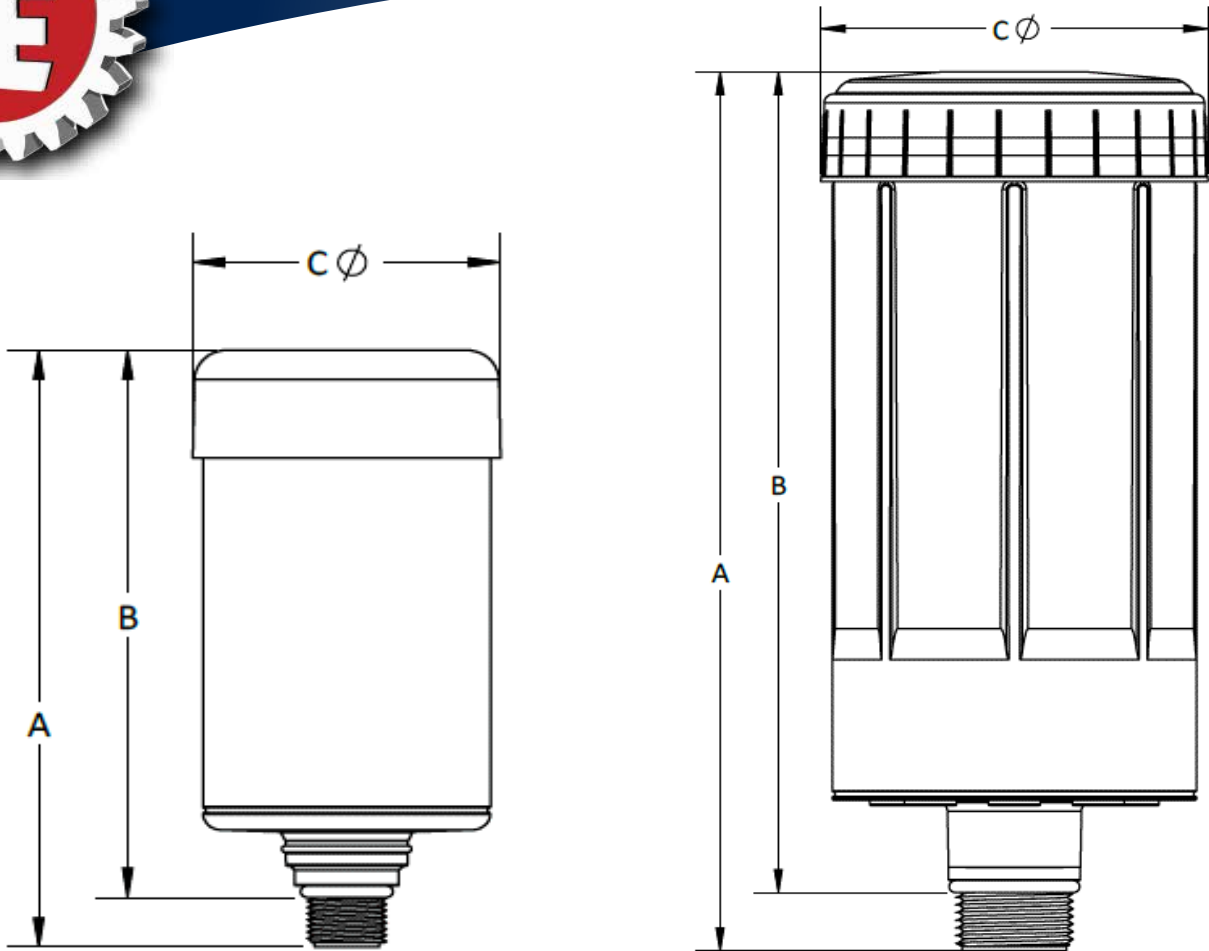

Breather Dimensions

Model	Style	Thread Size (Multi-Fit Male)	A (inch / mm)	B (inch / mm)	C (inch / mm)
LEXHHCV375-13	miniature	3/8" with O-Ring Seal, Compatible with: 3/8" NPT; 3/8" BSPT; 3/8" BSPP	3.87 / 98	3.43 / 87	2.52 / 64
LEXHHCV375-28			5.4 / 136	4.9 / 125	2.52 / 64
LEXHHCV1-66	standard	1" with O-Ring Seal, Compatible with: 1" NPT; 1" NPSM; 1" BSPT; 1" BSPP	6.0 / 152	5.33 / 135	4.1 / 104
LEXHHCV1-122			8.0 / 203	7.33 / 186	4.1 / 104
LEXHHCV1-188			10.0 / 254	9.33 / 237	4.1 / 104